



**DEDICATED POWER
EDGER**

Parts Catalog

MODEL 1304H, 1304B

<u>Description</u>	<u>Page Number</u>
Table of Contents	2
Honda Engine A	3
Briggs Engine A	4
Transmission Assembly	5
Transmission Service Parts	6
Edger Transmission Config.	7
Hydro Handle A – 10-0682	8
Frame A	9
Trans Frame Engine A	10
Lift Kit – K1305LK	11
Idler Arm A	12
Gearbox A	13
Gauge Wheel A – 10-0677	14
Cover Clamp A – 10-0671	15
Opener Trencher Shield	16
Fixed Frame Edger Front A	17
Arm A	18
1304 H Fixed Frame Edger	19
Opener/Trencher Blades – 10-0699	20

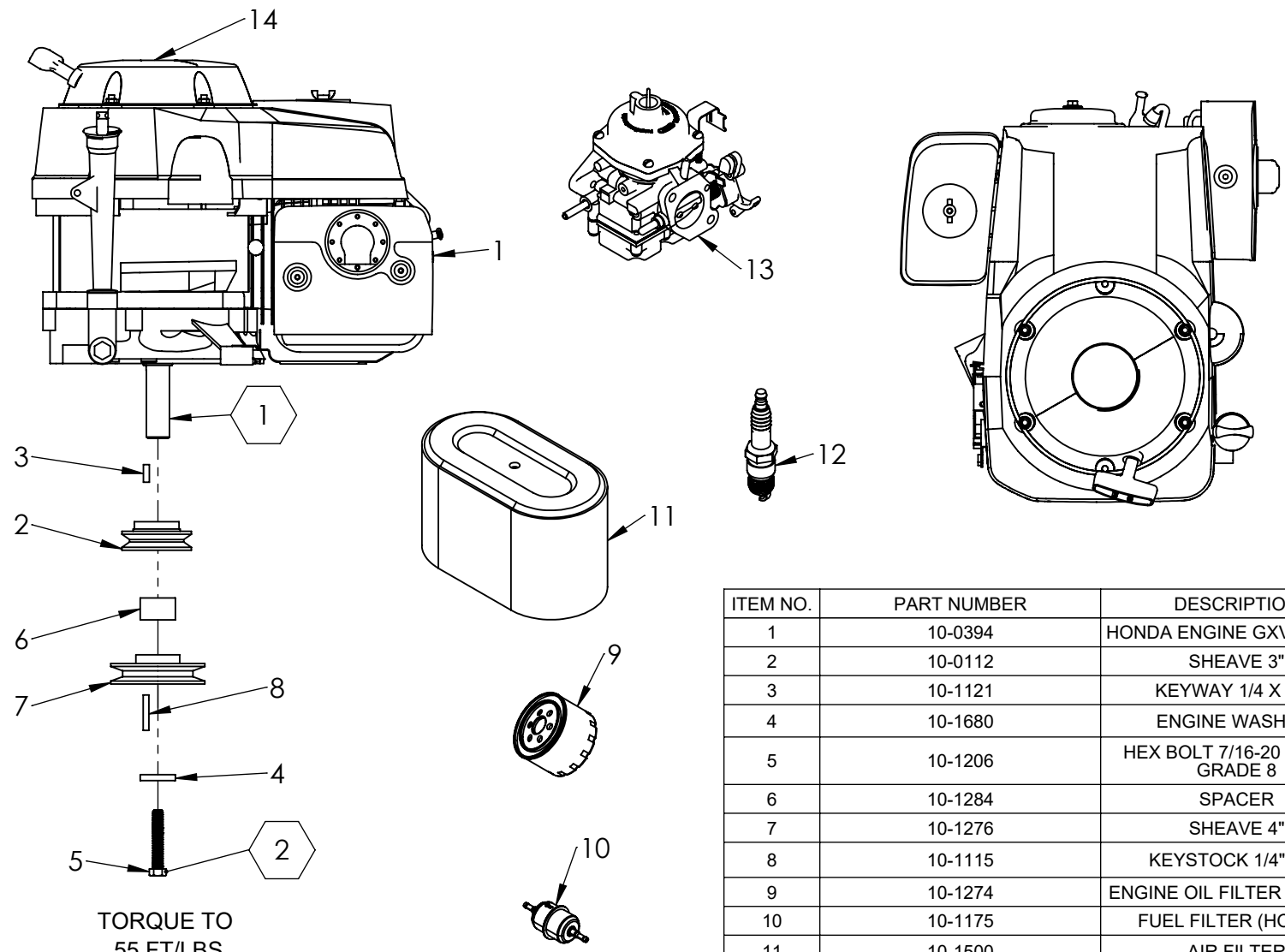

TORQUE TO
55 FT/LBS

1 APPLY ANTI-SEIZE LUBRICANT

2 APPLY LOCTITE 271 THREADLOCKER

NOTE: ALL HARDWARE IS GRADE 5, PLATED AND
COARSE THREAD UNLESS OTHERWISE SPECIFIED

ITEM NO.	PART NUMBER	DESCRIPTION	QTY.
1	10-0394	HONDA ENGINE GXV390DA23	1
2	10-0112	SHEAVE 3"	1
3	10-1121	KEYWAY 1/4 X .75"	1
4	10-1680	ENGINE WASHER	1
5	10-1206	HEX BOLT 7/16-20 X 1 1/2" GRADE 8	1
6	10-1284	SPACER	1
7	10-1276	SHEAVE 4"	1
8	10-1115	KEYSTOCK 1/4" X 1"	1
9	10-1274	ENGINE OIL FILTER (HONDA)	1
10	10-1175	FUEL FILTER (HONDA)	1
11	10-1500	AIR FILTER	1
12	10-1718	SPARK PLUG	1
13	10-1720	HONDA GXV390 CARBURETOR	1
14	10-1798	HONDA RECOIL STARTER ASSEMBLY	1

TURFTEQ	10-0667	04-01-19
	MODEL 1304 H	HONDA ENGINE A

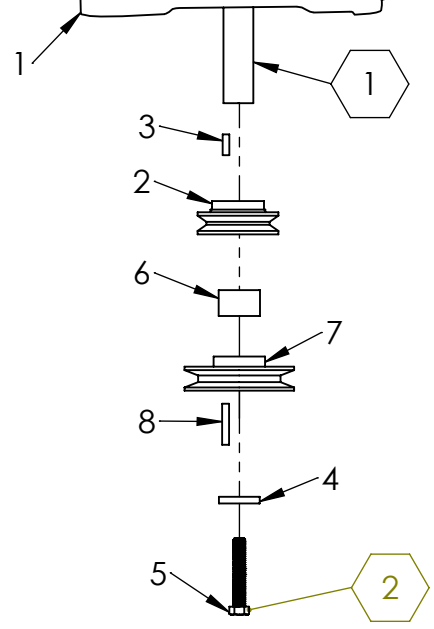
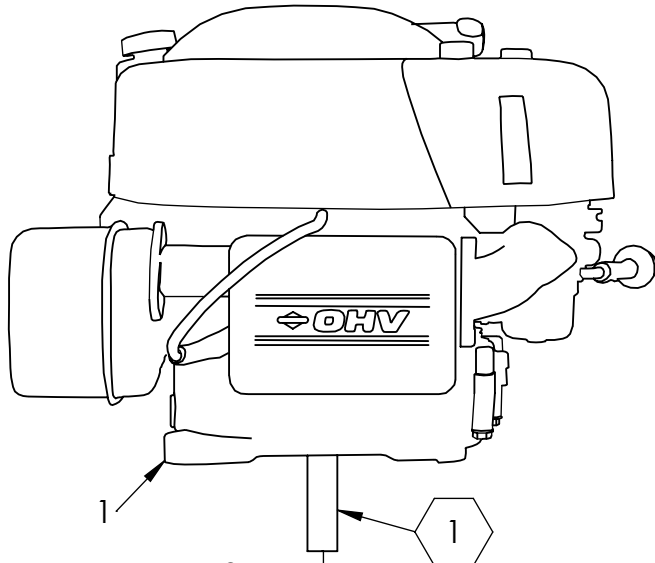

TORQUE TO
55 FT/LBS



APPLY ANTI-SEIZE LUBRICANT



APPLY LOCTITE 271 THREADLOCKER

ITEM NO.	PART NUMBER	DESCRIPTION	QTY.
1	10-1672 SUPERSEDES 10-1188 (S/N 1903 AND BELOW)	10.5 HP BRIGGS AND STRATTON ENGINE W/OUT GAS TANK	1
2	10-0112	SHEAVE 3"	1
3	10-1121	KEYWAY 1/4" X 3/4"	1
4	10-1680	ENGINE WASHER	1
5	10-1206	HEX BOLT 7/16"-20 X 1-1/2" GRADE 8	1
6	10-1284	SPACER	1
7	10-1276	SHEAVE 4"	1
8	10-1115	KEYSTOCK 1/4" X 1"	1

NOTE: ALL HARDWARE IS GRADE 5, PLATED AND COARSE THREAD UNLESS OTHERWISE SPECIFIED

TURFTEQ		6/20/18
MODEL 1304 B	BRIGGS ENGINE A	PAGE 4

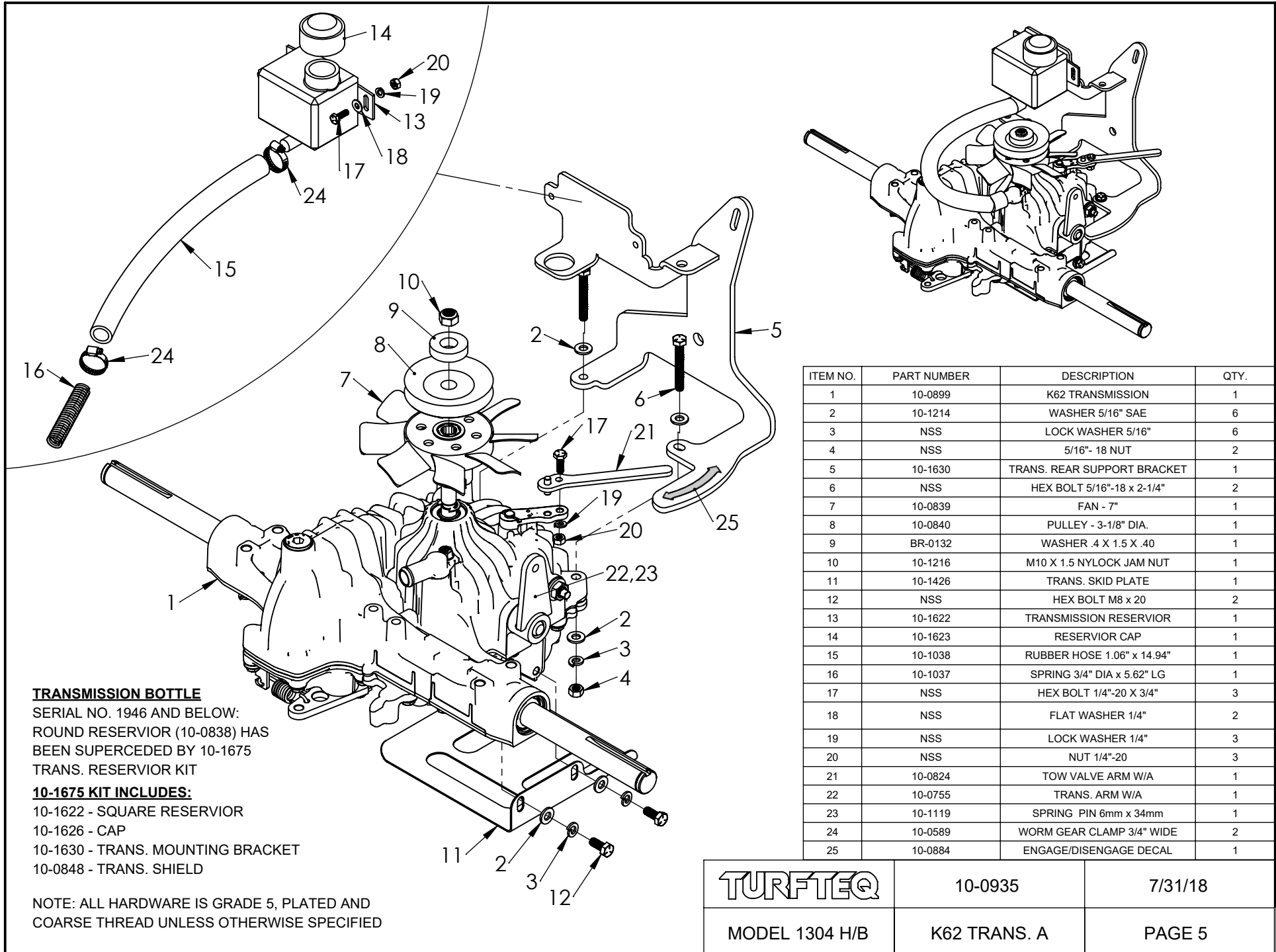

TRANSMISSION BOTTLE

SERIAL NO. 1946 AND BELOW:
 ROUND RESERVIOR (10-0838) HAS
 BEEN SUPERCEDED BY 10-1675
 TRANS. RESERVIOR KIT

10-1675 KIT INCLUDES:

- 10-1622 - SQUARE RESERVIOR
- 10-1626 - CAP
- 10-1630 - TRANS. MOUNTING BRACKET
- 10-0848 - TRANS. SHIELD

NOTE: ALL HARDWARE IS GRADE 5, PLATED AND
 COARSE THREAD UNLESS OTHERWISE SPECIFIED

ITEM NO.	PART NUMBER	DESCRIPTION	QTY.
1	10-0899	K62 TRANSMISSION	1
2	10-1214	WASHER 5/16" SAE	6
3	NSS	LOCK WASHER 5/16"	6
4	NSS	5/16"- 18 NUT	2
5	10-1630	TRANS. REAR SUPPORT BRACKET	1
6	NSS	HEX BOLT 5/16"-18 x 2-1/4"	2
7	10-0839	FAN - 7"	1
8	10-0840	PULLEY - 3-1/8" DIA.	1
9	BR-0132	WASHER .4 X 1.5 X .40	1
10	10-1216	M10 X 1.5 NYLOCK JAM NUT	1
11	10-1426	TRANS. SKID PLATE	1
12	NSS	HEX BOLT M8 x 20	2
13	10-1622	TRANSMISSION RESERVIOR	1
14	10-1623	RESERVIOR CAP	1
15	10-1038	RUBBER HOSE 1.06" x 14.94"	1
16	10-1037	SPRING 3/4" DIA x 5.62" LG	1
17	NSS	HEX BOLT 1/4"-20 X 3/4"	3
18	NSS	FLAT WASHER 1/4"	2
19	NSS	LOCK WASHER 1/4"	3
20	NSS	NUT 1/4"-20	3
21	10-0824	TOW VALVE ARM W/A	1
22	10-0755	TRANS. ARM W/A	1
23	10-1119	SPRING PIN 6mm x 34mm	1
24	10-0589	WORM GEAR CLAMP 3/4" WIDE	2
25	10-0884	ENGAGE/DISENGAGE DECAL	1

TURFTEQ	10-0935	7/31/18
	MODEL 1304 H/B	K62 TRANS. A

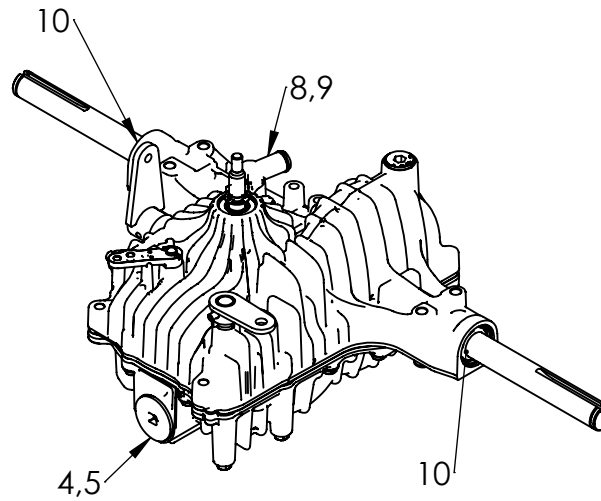
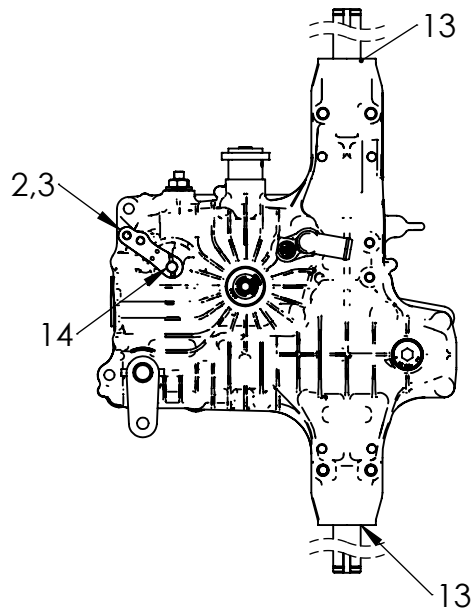

10-1419 - SEAL KIT
 INCLUDES ALL O-RINGS,
 GASKETS, AXLE SEALS,
 FILTERS, AND RTV GASKET
 SEALANT

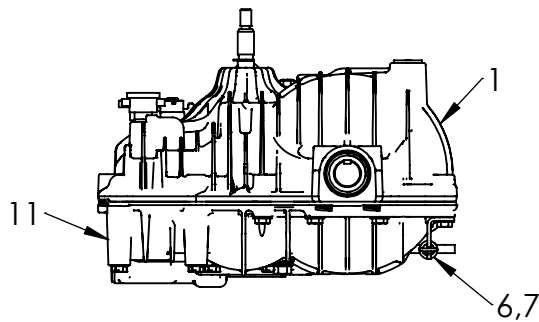
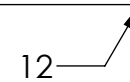

ITEM NO.	PART NUMBER	DESCRIPTION	Default/QTY.
1	10-0899	K62 TRANSMISSION	1
2	10-1245	HYDRO RELEASE LEVER	1
3	10-1247	HYDRO RELEASE SPRING LOCK RETAINING PIN	1
4	10-1251	DRAIN PLUG	1
5	10-1252	O-RING	1
6	10-1253	DIFFERENTIAL LOCK LEVER	1
7	10-1254	O-RING - 2	1
8	10-1255	OIL INLET	1
9	10-1256	OIL INLET O-RING	1
10	10-1414	AXLE SEAL - MODEL 1305 - K62	2
11	10-1418	K62 TRANSMISSION LOWER CASE	1
12	10-1419	K62 TRANSMISSION SEAL KIT	1
13	10-1530	AXLE BUSHING	2
14	10-1531	O-RING - HYDRO RELEASE	1

TURFTEQ

11/16/18

MODEL 1304 H/B

TRANS. SERVICE PARTS

PAGE 6

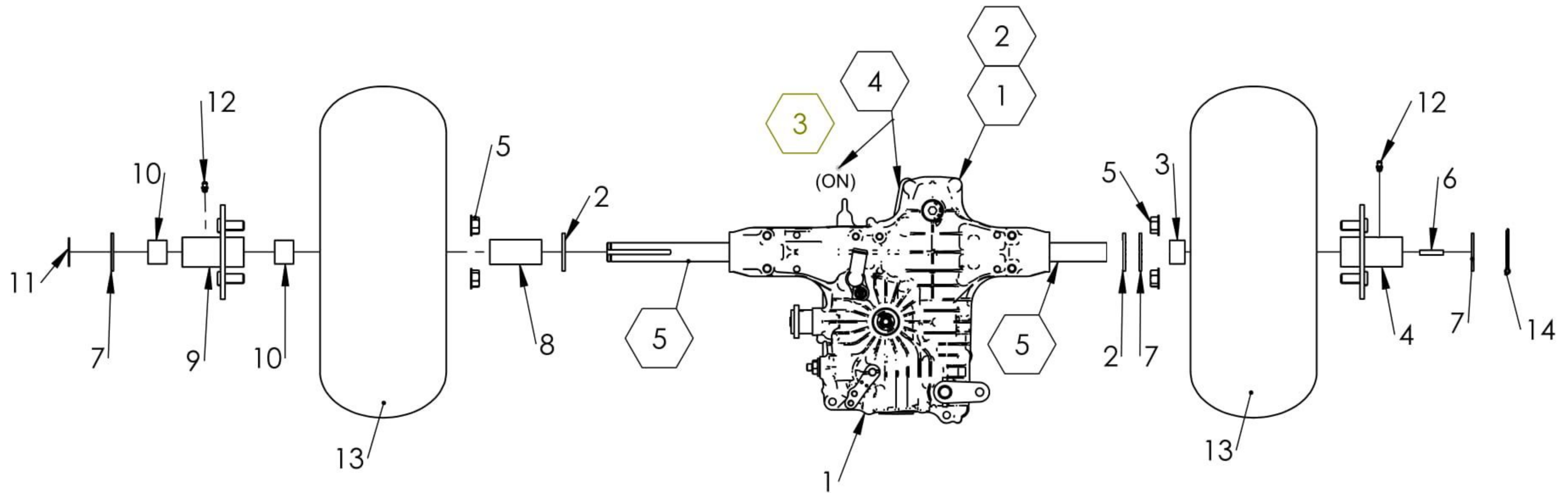

TRANSMISSION CONFIGURATION FOR 1304 DEDICATED EDGER
DIFF LOCK ARM POSITIONING

- 1** REMOVE SPRING AND SPRING MOUNTING BRACKET FROM TRANSMISSION. REINSTALL HARDWARE WITH AN ADDITIONAL 5/16" WASHER
- 2** BEND SPRING MOUNTING BRACKET FROM 90° TO 108°
- 3** PIVOT DIFF-LOCK CONTROL ARM COMPLETELY OUT (AS SHOWN) THEN REINSTALL SPRING MOUNTING BRACKET AT POSITION TO HOLD DIFF-LOCK ARM OUT IN THE "ON" POSITION
- 5** APPLY ANTI-SEIZE LUBRICANT

ITEM NO.	PART NUMBER	DESCRIPTION	QTY.
1	10-0935	K62 TRANSMISSION A	1
2	10-1217	1" SAE WASHER	2
3	10-0875	SPACER	1
4	10-0847	WHEEL HUB	1
5	10-1219	1/2"-20 LUG NUT	8
6	10-1116	KEY 1/4" x 1.25"	2
7	10-1110	WASHER MACHINE	3
8	10-0892	SPACER 2.75" LG	1
9	10-1097	WHEEL HUB BUSHING	1
10	10-0104	BRONZE BUSHING	2
11	10-1113	E-CLIP	1
12	10-1120	ZERK FITTING	2
13	10-0846	TIRE AND RIM A	2
14	10-1222	1/8" x 1-3/4" COTTER PIN	1

TURFTEQ

8/3/18

NOTE: DOES NOT INCLUDE DIFF-LOCK OR WHEEL LOCK KITS. ALL HARDWARE IS GRADE 5, PLATED AND COARSE THREAD UNLESS OTHERWISE SPECIFIED

MODEL 1304 H/B

EDGER TRANS. CONFIG.

PAGE 7

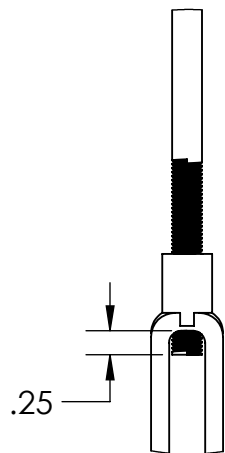
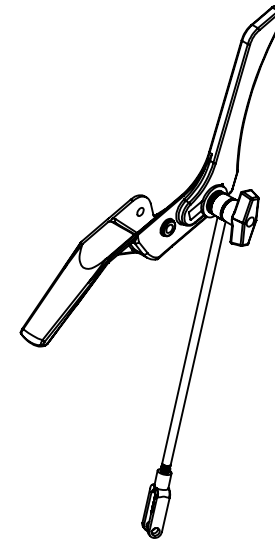
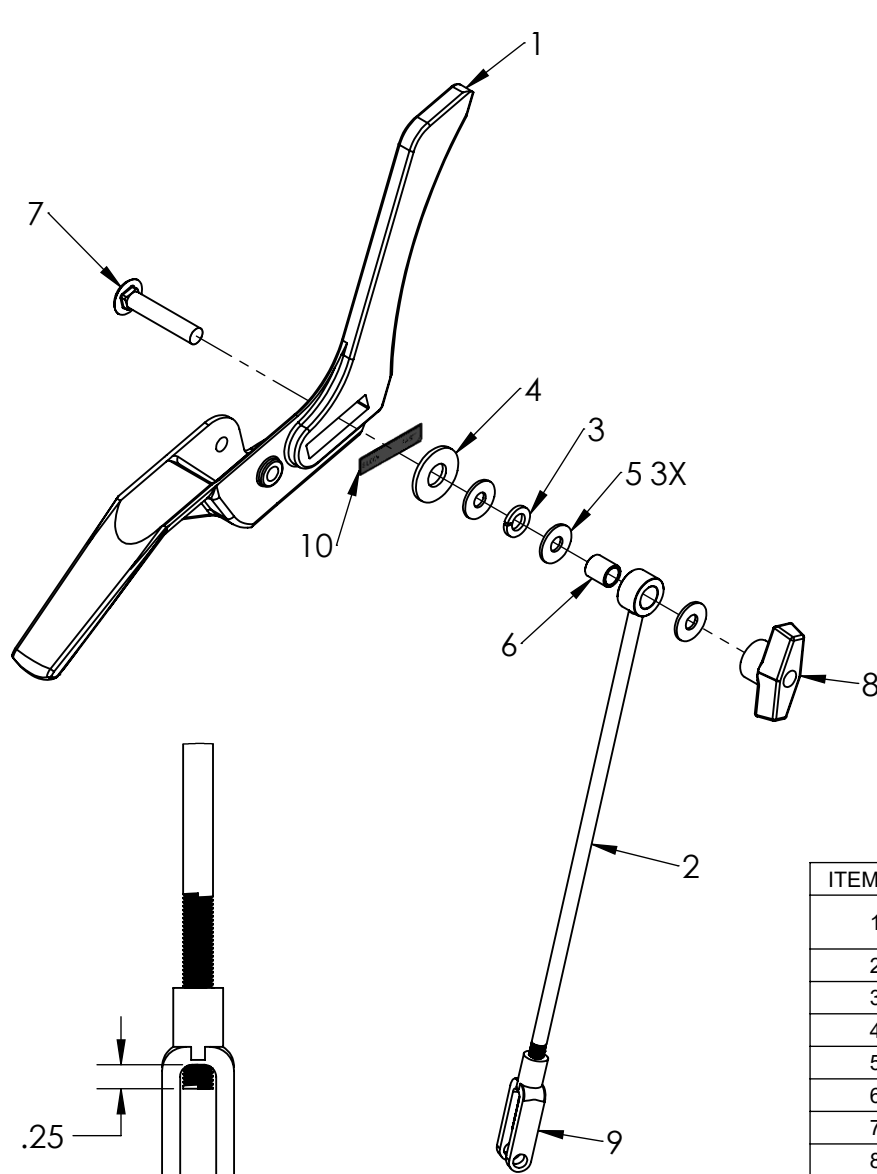

DEFAULT YOKE
CONFIGURATION

ITEM NO.	PART NUMBER	DESCRIPTION	QTY.
1	10-1737	HYDRO HANDLE SUPERCEDES 10-0254	1
2	10-0881	ROD WA	1
3	NSS	3/8" LOCK WASHER	1
4	NSS	1/2" FLAT WASHER	1
5	NSS	5/16" USS FLAT WASHER	3
6	10-0619	SLEEVE	1
7	NSS	3/8"-16 x 2" LG CARRIAGE BOLT	1
8	10-0664	KNOB	1
9	10-0449	YOKE	1
10	10-0447	DECAL - TRAVEL SPEED	1

TURFTEQ

10-0682

11/15/18

MODEL 1304 H/B

HYDRO HANDLE A

PAGE 8

ITEM NO.	PART NUMBER	DESCRIPTION	QTY.
1	10-1670	MAIN FRAME SUPERCEDES 10-0191 S/N: 01903 & BELOW	1
2	10-0682	HYDRO HANDLE ASSY.	1
3	10-0855	HYDRO HANDLE LINK	1
4	10-0190	HANDLE GRIP	2
5	10-1227	T-HANDLE	1
6	10-1600	CABLE BRACKET	1
7	10-1616	2.5 GALLON FUEL TANK S/N: 01904 & ABOVE	1
7	10-0264	1 GALLON FUEL TANK S/N: 01903 & BELOW	1
8	10-1624	FUEL TANK MTG. BRACKET S/N: 01904 & ABOVE	1
9	10-0339	HYDRO PIVOT BRACKET LH	1
10	10-0340	HYDRO PIVOT BRACKET RH	1
11	10-1617	2.5 GALLON FUEL TANK CAP S/N: 01904 & ABOVE	1
12	10-0135	THROTTLE CABLE	1
13	10-1618	FUEL LINE SUPPLY - 19" S/N: 01904 & ABOVE	1
14	10-1619	FUEL LINE EMISSION - 48" S/N: 01904 & ABOVE	1
15	10-1739	CLUTCH HANDLE SUPERCEDES 10-1400	1
16	10-1270	CLUTCH CABLE W/SPRING	1
17	NSS	HEX BOLT 1/4-20 x 3/4" LG	2
18	NSS	1/4" FLAT WASHER	4
19	NSS	1/4" LOCK WASHER	2
20	NSS	1/4"-20 NUT	2
21	10-1407	CLAMP BAR	1
22	NSS	HEX BOLT 5/16"-18 x 1.00"LG	2
23	NSS	5/16" FLAT WASHER	8
24	NSS	5/16" LOCK WASHER	6
25	NSS	5/16"-18 HEX NUT	6
26	NSS	CARRIAGE BOLT 5/16"-18 x 3/4" LG	4
27	NSS	HEX BOLT 5/16"-18 x 2-1/4"LG	2
28	10-1225	5/16"-18 LOCK NUT	2
29	10-1395	MODEL 1304H DECAL	1
30	10-0439	WARNING DECAL	1
31	10-0441	CHOKE-RUN-IDLE-STOP DECAL	1
32	10-1376	"MADE IN THE USA" DECAL	1
33	10-0446	ENGAGE DISENGAGE DECAL	1
34	10-0448	FORWARD REVERSE DECAL	1
35	10-1415	GASOLINE/PPE DECAL	1
36	10-1671	CONVERT 1 GAL. FUEL TANK TO 2.5 GAL. FUEL TANK	1
37	10-1230	CONSTANT-TENSION SPRING HOSE CLAMP	4
38	10-0615	5/16" x 1.00" CLEVIS PIN	1
39	10-1434	HAIR PIN COTTER 1/8" X 1-3/4"	1
40	NSS	5/16"-18 x 1.00"LG CARRIAGE BOLT	1
41	NSS	5/16"-18 JAM NUT	1
42	NSS	HEX BOLT 5/16"-18 x 2.50" LG	1
43	NSS	PAN HEAD MACHINE SCREW #10 x .75"	2
44	NSS	#10 WASHER	2
45	NSS	#10 LOCK WASHER	2
46	NSS	#10 NUT	2

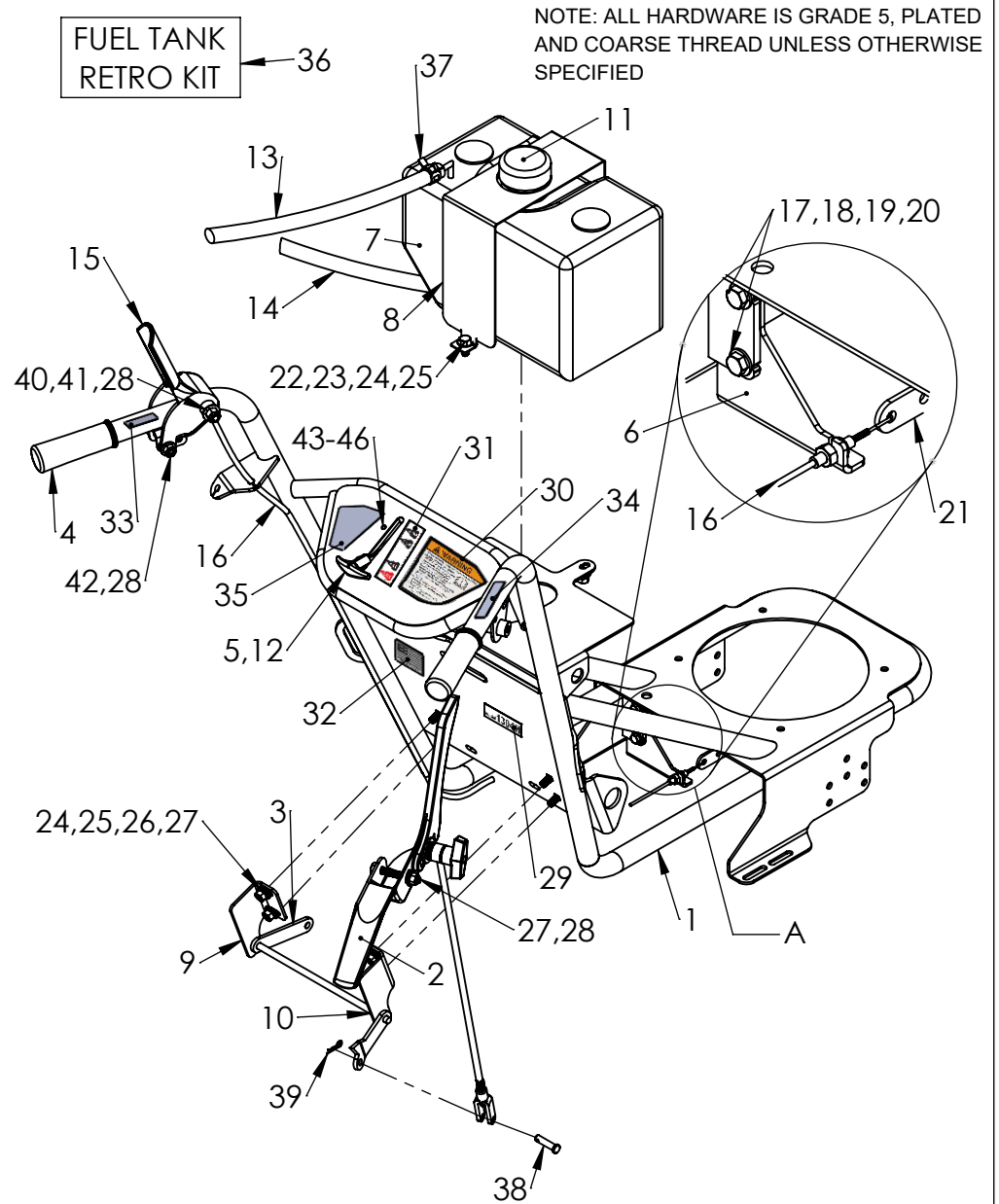

TURFTEQ		11/15/18
MODEL 1304 H/B	FRAME A	PAGE 9

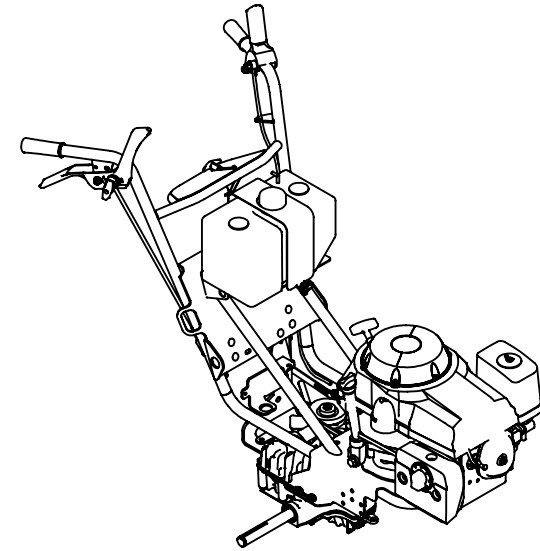
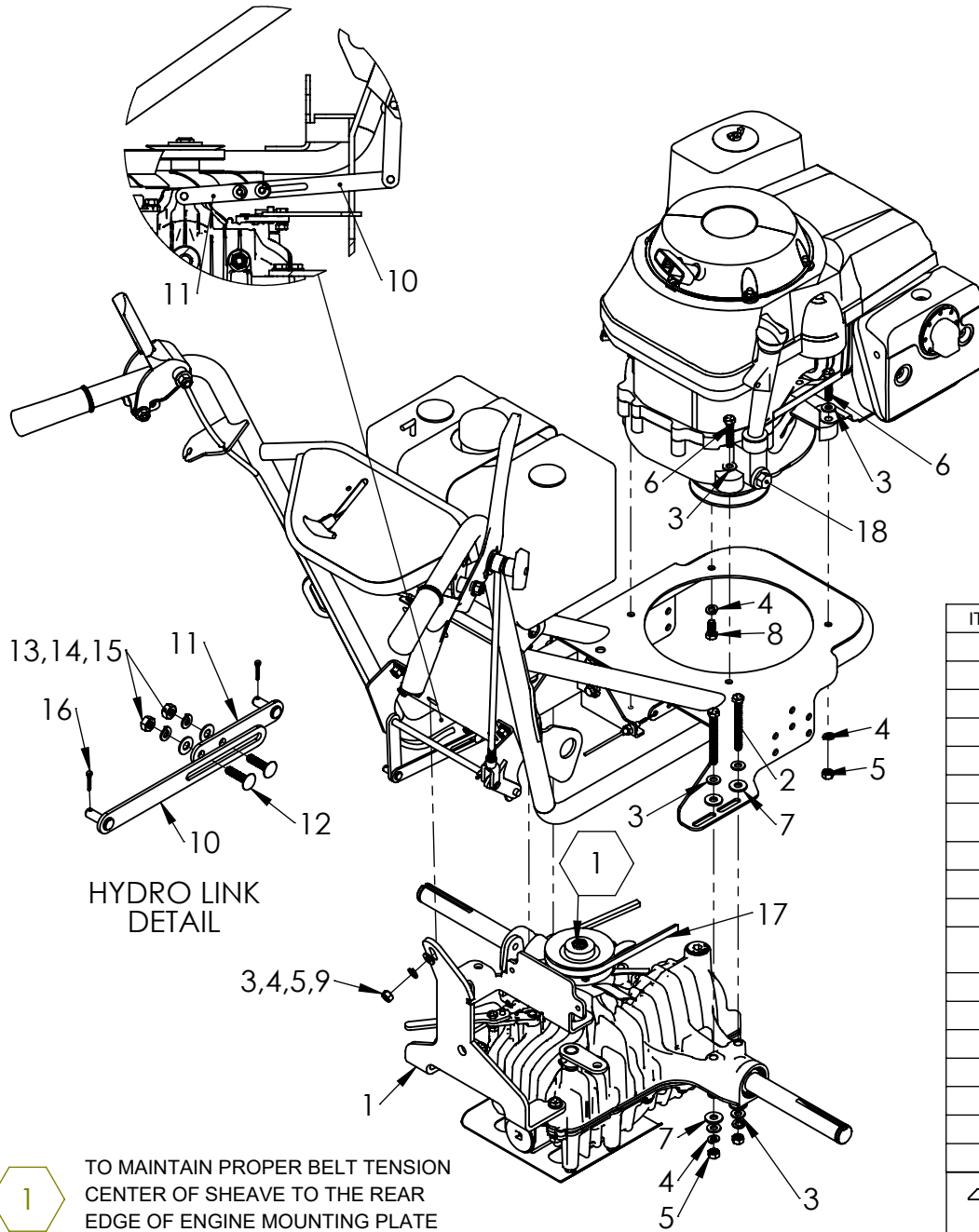

ITEM NO.	PART NUMBER	DESCRIPTION	QTY.
1	10-0935	K62 TRANSMISSION A	1
2	NSS	HEX BOLT 5/16-18 X 3.00" LG	4
3	10-1214	5/16" SAE WASHER	11
4	NSS	5/16" LOCK WASHER	9
5	NSS	5/16"-18 HEX NUT	7
6	NSS	HEX BOLT 5/16-18 X 1.50" LG	2
7	NSS	5/16" USS FLAT WASHER	8
8	10-1226	HEX BOLT 5/16-24 X .75" LG	2
9	NSS	5/16-18 X 1" LG CARRIAGE BOLT	1
10	10-1406	SLIDE ADJUSTMENT BAR	1
11	10-1407	CLAMP BAR W.A.(ADJUSTABLE TRANS LINK)	1
12	NSS	1/4-20 X 3/4" LG CARRIAGE BOLT	2
13	NSS	1/4" FLAT WASHER	2
14	NSS	1/4" LOCK WASHER	2
15	NSS	1/4-20 HEX NUT	2
16	10-1210	1/8" X 3/4" LG COTTER PIN	2
17	10-0902	TRANS. V-BELT	1
18	NSS	HEX BOLT 5/16"-18 x 2.00" LG	1



TO MAINTAIN PROPER BELT TENSION
 CENTER OF SHEAVE TO THE REAR
 EDGE OF ENGINE MOUNTING PLATE
 IS TO BE 3-3/4"

TURFTEQ

11/15/18

MODEL 1304 H/B

TRANS FRAME ENGINE

PAGE 10

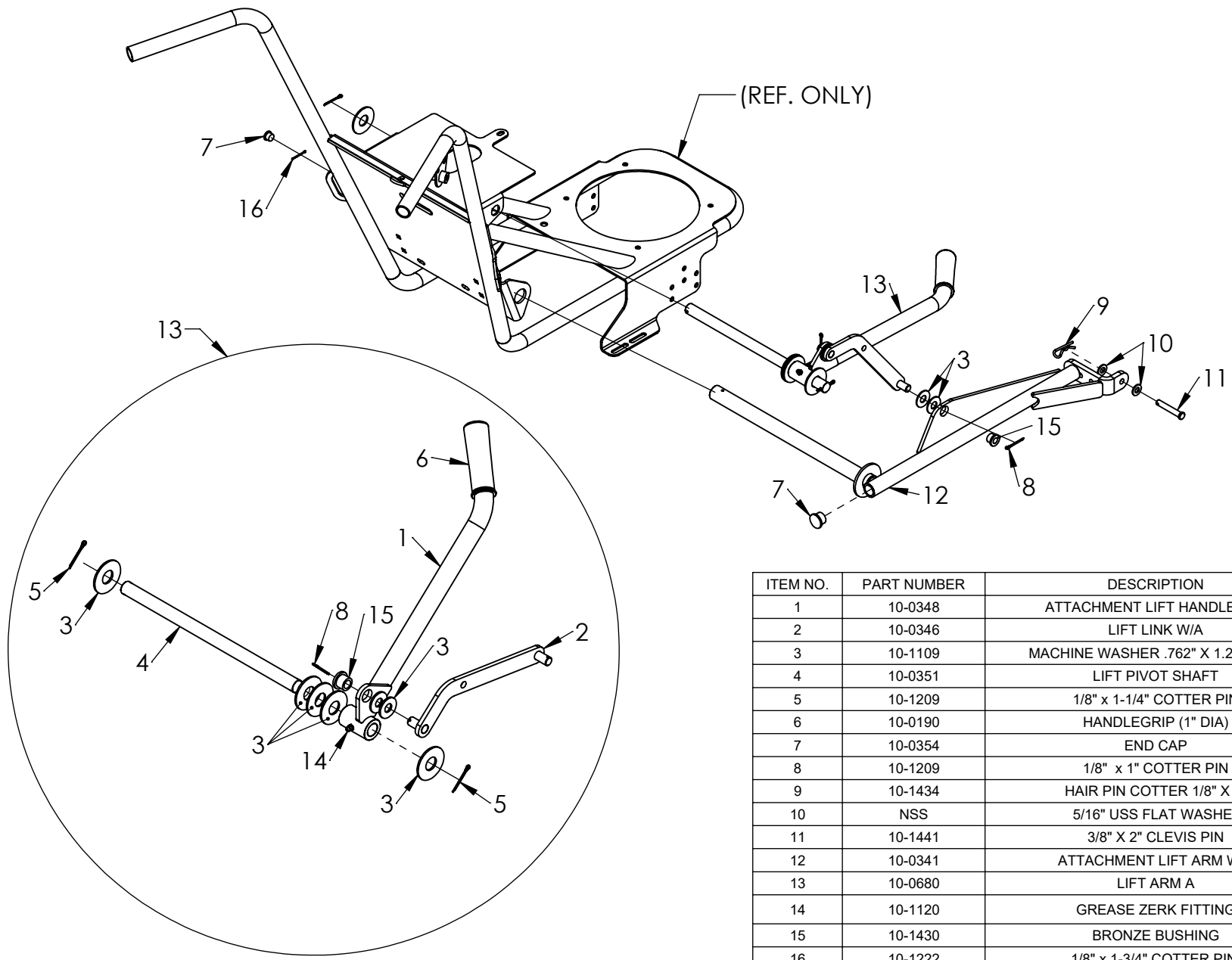

NOTE: ALL HARDWARE IS GRADE 5, PLATED AND COARSE THREAD UNLESS OTHERWISE SPECIFIED

ITEM NO.	PART NUMBER	DESCRIPTION	QTY.
1	10-0348	ATTACHMENT LIFT HANDLE W/A	1
2	10-0346	LIFT LINK W/A	1
3	10-1109	MACHINE WASHER .762" X 1.25" X .07	9
4	10-0351	LIFT PIVOT SHAFT	1
5	10-1209	1/8" x 1-1/4" COTTER PIN	3
6	10-0190	HANDLEGRIP (1" DIA)	1
7	10-0354	END CAP	1
8	10-1209	1/8" x 1" COTTER PIN	2
9	10-1434	HAIR PIN COTTER 1/8" X 1"	1
10	NSS	5/16" USS FLAT WASHER	2
11	10-1441	3/8" X 2" CLEVIS PIN	1
12	10-0341	ATTACHMENT LIFT ARM W/A	1
13	10-0680	LIFT ARM A	1
14	10-1120	GREASE ZERK FITTING	1
15	10-1430	BRONZE BUSHING	2
16	10-1222	1/8" x 1-3/4" COTTER PIN	1

TURFTEQ	K1305LK	11/15/18
	MODEL 1304 H/B	LIFT KIT A
		PAGE 11

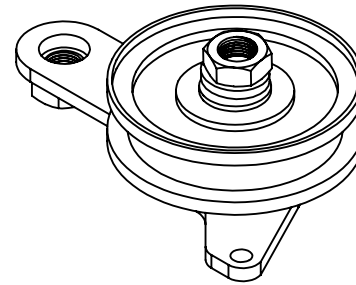
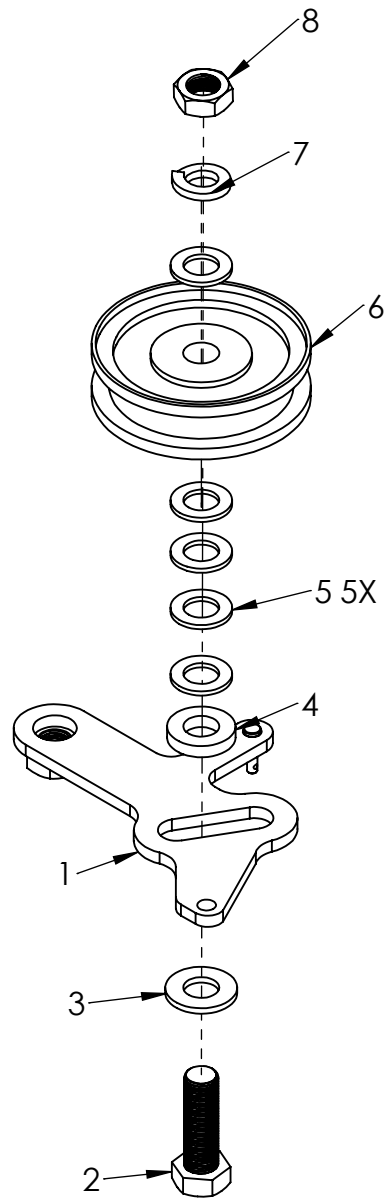

ITEM NO.	PART NUMBER	DESCRIPTION	QTY.
1	10-1192	IDLER ARM W/A	1
2	NSS	HEX BOLT 5/8"-11 X 2" LG	1
3	NSS	5/8" FLAT WASHER	1
4	10-0693	SPACER	1
5	10-1108	5/8" MACHINE WASHER	5
6	10-0501	FLAT IDLER PULLEY	1
7	NSS	5/8" LOCK WASHER	1
8	10-1212	5/8"-11 JAM NUT	1

NOTE: ALL HARDWARE IS GRADE 5, PLATED AND COARSE
 THREAD UNLESS OTHERWISE SPECIFIED

TURFTEQ

10-1682

7/9/18

MODEL 1304 H/B

IDLER ARM A

PAGE 12

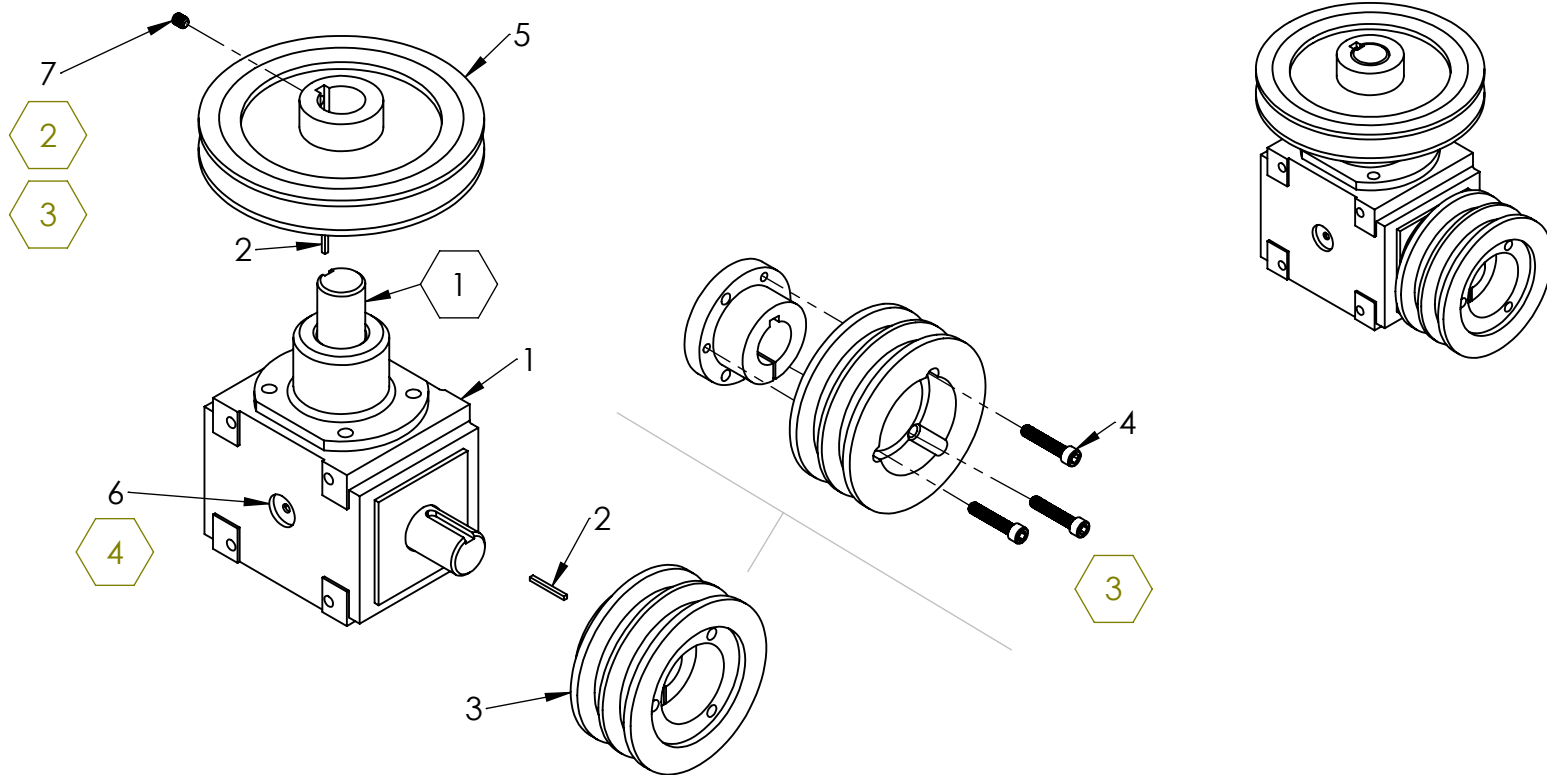

- 4** FILL TO PLUG WITH 80w90 OIL.
- 3** HARDWARE SUPPLIED BY VENDOR
- 2** APPLY LOCTITE 242 (BLUE) THREADLOCKER TO ALL SET SCREWS
- 1** APPLY ANTI-SEIZE LUBRICANT

ITEM NO.	PART NUMBER	DESCRIPTION	QTY.
1	10-0565	GEARBOX	1
2	10-1116	KEYWAY 1/4 X 1-1/4	2
3	10-0648	SHEAVE 4"	1
4	NSS	DIA. 1/4-20 x 1-1/4 SHCS INCLUDED IN PN: 10-0648	3
5	10-0225	SHEAVE 6" DIA.	1
6	10-1208	OIL FILL PLUG	1
7	10-1236	5/16 x 3/8 SET SCREW INCLUDED IN PN 10-0225	1

TURFTEQ

10-0676

11/2/17

MODEL 1304 H/B

GEARBOX A

PAGE 13

NOTE: ALL HARDWARE IS GRADE 5, PLATED AND COARSE THREAD UNLESS OTHERWISE SPECIFIED

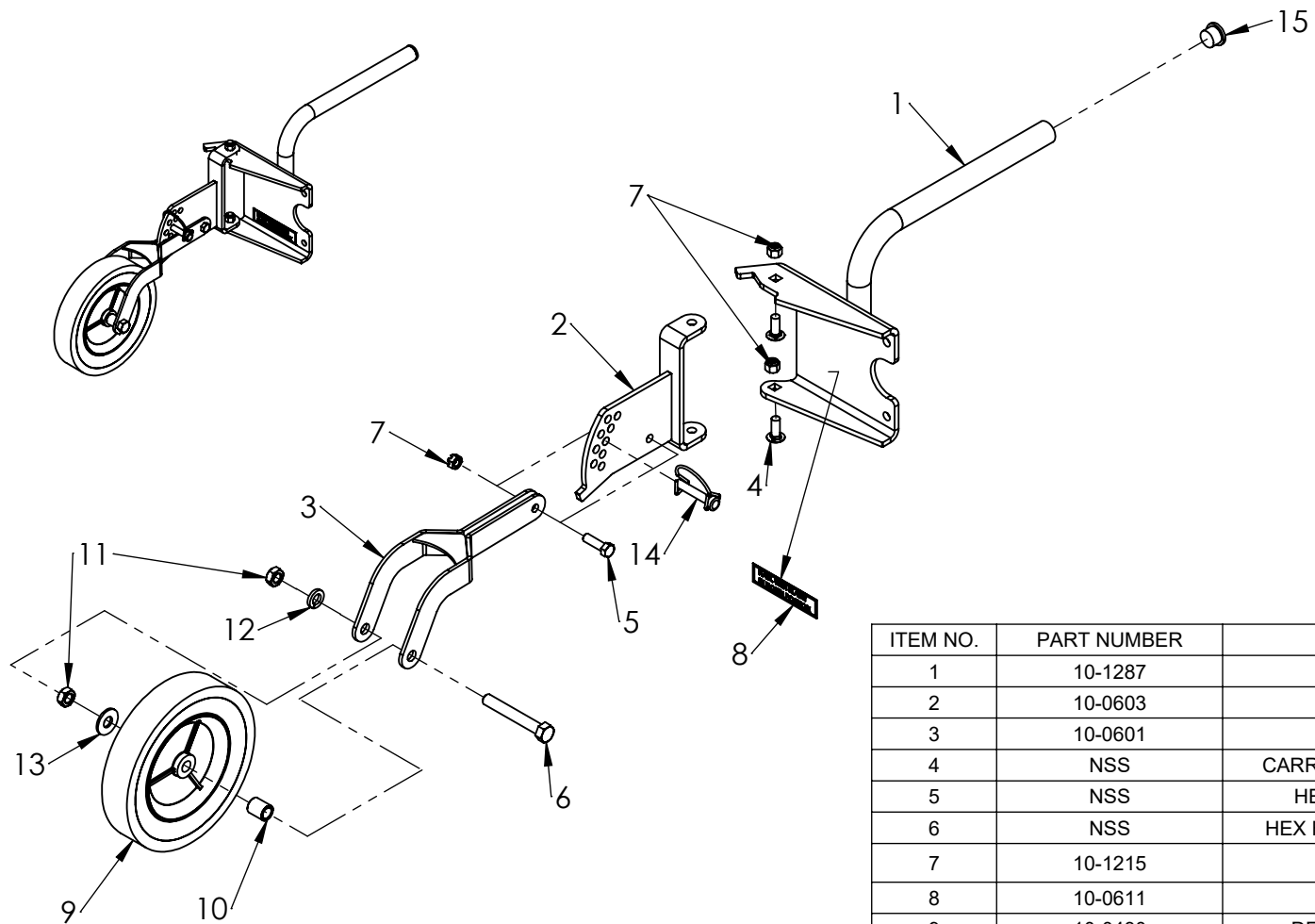

ITEM NO.	PART NUMBER	DESCRIPTION	QTY.
1	10-1287	BELT GUARD	1
2	10-0603	PIVOT PLATE WA	1
3	10-0601	DOLLY ARM WA	1
4	NSS	CARRIAGE BOLT 3/8" X 1-1/4"	2
5	NSS	HEX BOLT 3/8" X 1-1/4"	1
6	NSS	HEX BOLT 1/2"-13 x 3-1/2" LG	1
7	10-1215	LOCK NUT 3/8"	3
8	10-0611	DECAL	1
9	10-0430	DEPTH CONTROL TIRE	1
10	10-0663	SPACER	1
11	10-1204	JAM NUT 1/2"-13	2
12	NSS	LOCK WASHER 1/2"	1
13	10-1107	FLAT WASHER 1/2" SAE	1
14	10-0574	SNAP PIN 3/8" X 1.37	1
15	10-0354	END PLUG	1

TURFTEQ

10-0677

11/2/17

MODEL 1304H/B

GAUGE WHEEL A

PAGE 14

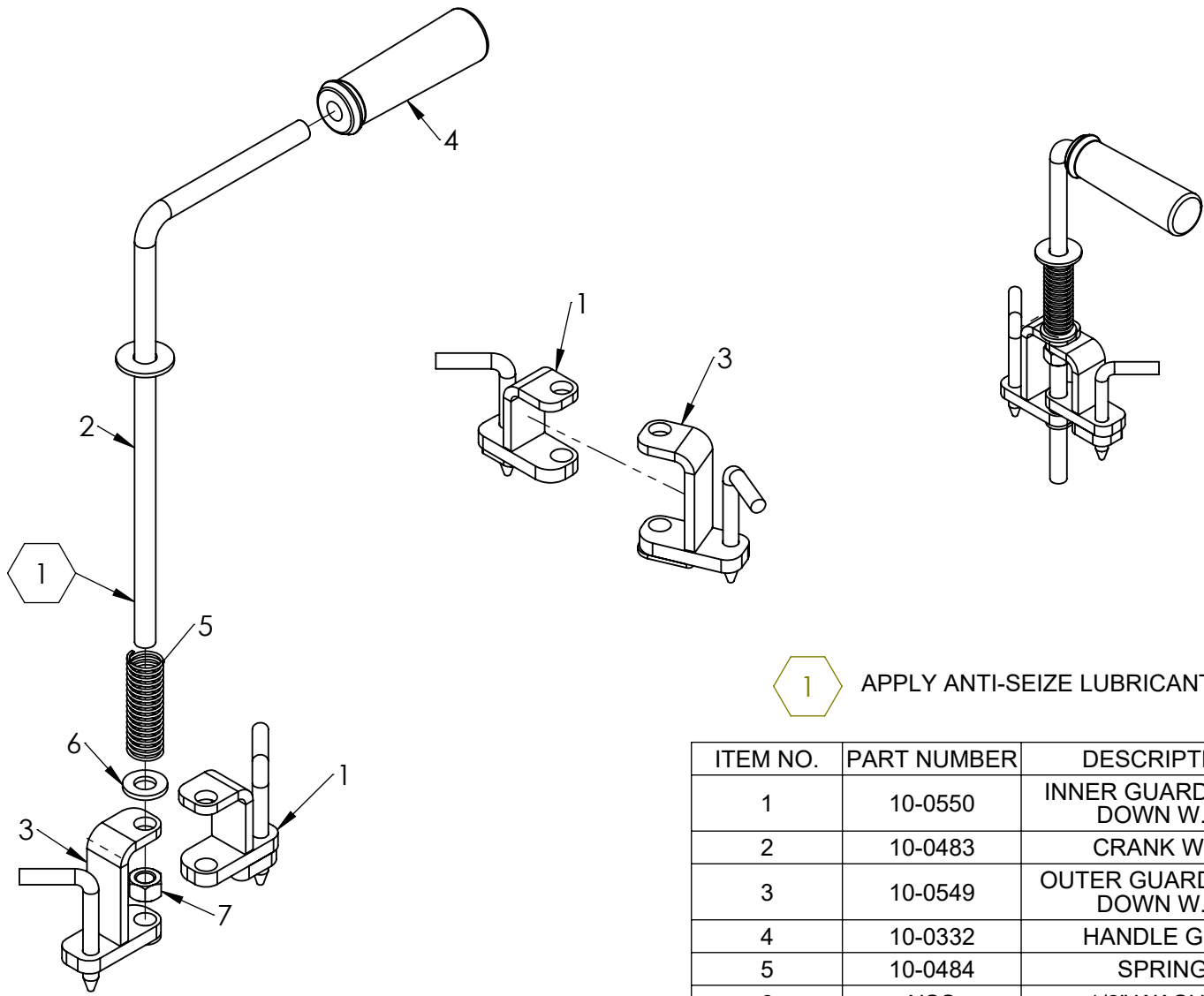

1 APPLY ANTI-SEIZE LUBRICANT TO THREADS

ITEM NO.	PART NUMBER	DESCRIPTION	QTY.
1	10-0550	INNER GUARD HOLD DOWN W.A.	1
2	10-0483	CRANK W.A.	1
3	10-0549	OUTER GUARD HOLD DOWN W.A.	1
4	10-0332	HANDLE GRIP	1
5	10-0484	SPRING	1
6	NSS	1/2" WASHER	1
7	NSS	1/2-13 HEX NUT	1

NOTE: ALL HARDWARE IS GRADE 5, PLATED AND COARSE THREAD UNLESS OTHERWISE SPECIFIED

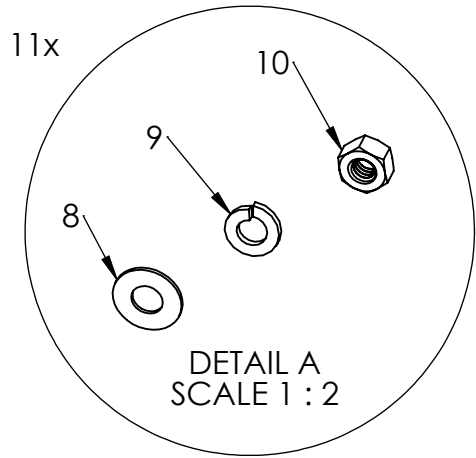
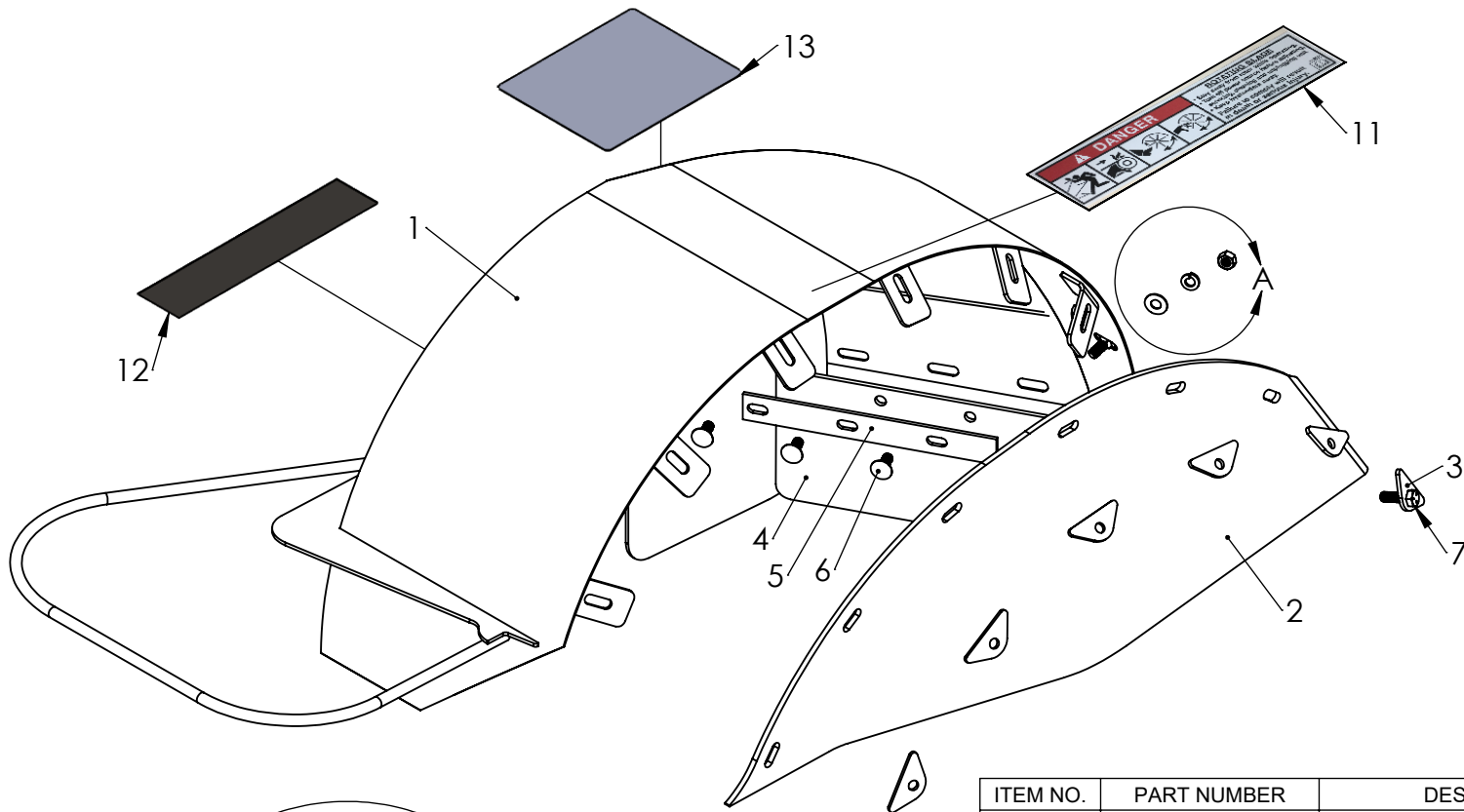

ITEM NO.	PART NUMBER	DESCRIPTION	Default/QTY.
1	10-0424	OPENER/ TRENCHER SHIELD W.A.	1
2	10-0491	COVER	1
3	10-0646	CLIP	6
4	10-0380	FLAP	1
5	10-0388	STRAP	1
6	NSS	CARRIAGE BOLT 5/16-18 x 3/4"LG	5
7	NSS	HEX BOLT 5/16-18 x 1"LG	6
8	10-1214	5/16" SAE WASHER	11
9	NSS	5/16" LOCK WASHER	11
10	NSS	5/16-18 NUT	11
11	10-0437	DECAL - DANGER	1
12	10-0445	DECAL - BLADE ROTATION	1
13	10-0440	DECAL - BELT CONFIGURATION	1

NOTE: ALL HARDWARE IS GRADE 5, PLATED AND COARSE THREAD UNLESS OTHERWISE SPECIFIED

TURFTEQ	G2	7/9/18
	MODEL 1304 H	OPENER/TRENCHER SHIELD (G2)

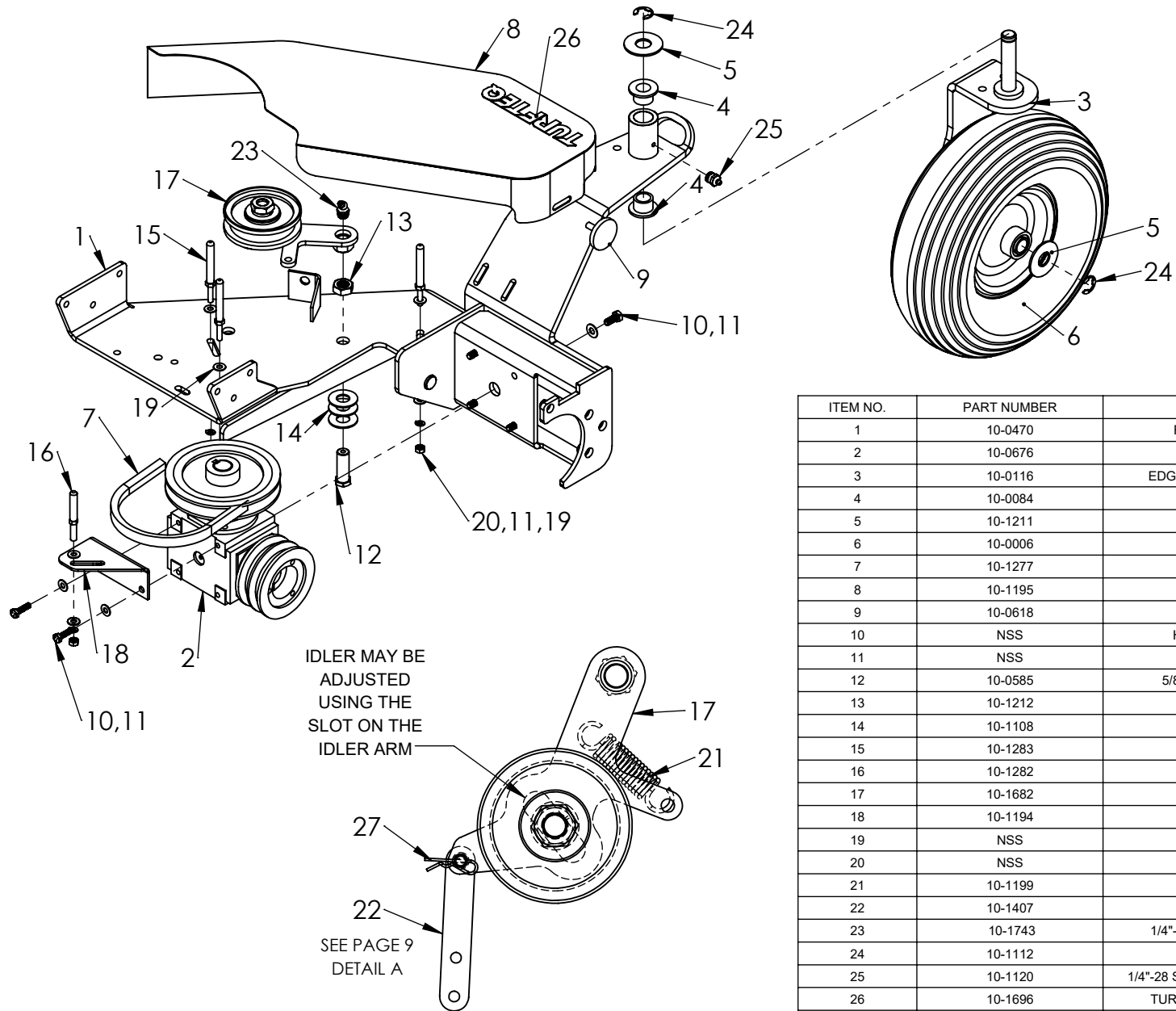

NOTE: ALL HARDWARE IS GRADE 5, PLATED AND COARSE THREAD UNLESS OTHERWISE SPECIFIED

ITEM NO.	PART NUMBER	DESCRIPTION	QTY.
1	10-0470	FIXED FRAME FRONT W/A	1
2	10-0676	GEARBOX A	1
3	10-0116	EDGER FRONT WHEEL DOLLY W/A	1
4	10-0084	BRONZE BUSHING	2
5	10-1211	3/4" MACHINE WASHER	2
6	10-0006	FRONT DOLLY WHEEL	1
7	10-1277	V-BELT - 58x470	1
8	10-1195	1304 BELT COVER W/A	1
9	10-0618	SHIELD KNOB	2
10	NSS	HEX BOLT 5/16-18 x 3/4" LG	6
11	NSS	5/16" LOCK WASHER	10
12	10-0585	5/8" x 1.75" DRILLED TAP BOLT	1
13	10-1212	5/8" JAM NUT	1
14	10-1108	5/8" MACHINE WASHER	3
15	10-1283	2.5"LG BELT GUIDE PIN	3
16	10-1282	1.75"LG BELT GUIDE PIN	1
17	10-1682	IDLER ARM ASSEMBLY	1
18	10-1194	BELT GUIDE BRACKET	1
19	NSS	5/16" USS FLAT WASHER	8
20	NSS	5/16"-18 HEX NUT	4
21	10-1199	EXTENSION SPRING	1
22	10-1407	CLAMP BAR W/A	1
23	10-1743	1/4"-28 45° GREASE ZERK FITTING	1
24	10-1112	3/4" E-CLIP	2
25	10-1120	1/4"-28 STRAIGHT GREASE ZERK FITTING	1
26	10-1696	TURF TEQ POWER EDGER DECAL	1
27	10-1434	1/8" x 1-3/4" HAIRPIN COTTER	1

TURFTEQ

11/6/18

MODEL 1304 H/B

FIXED FRAME FRONT A

PAGE 17

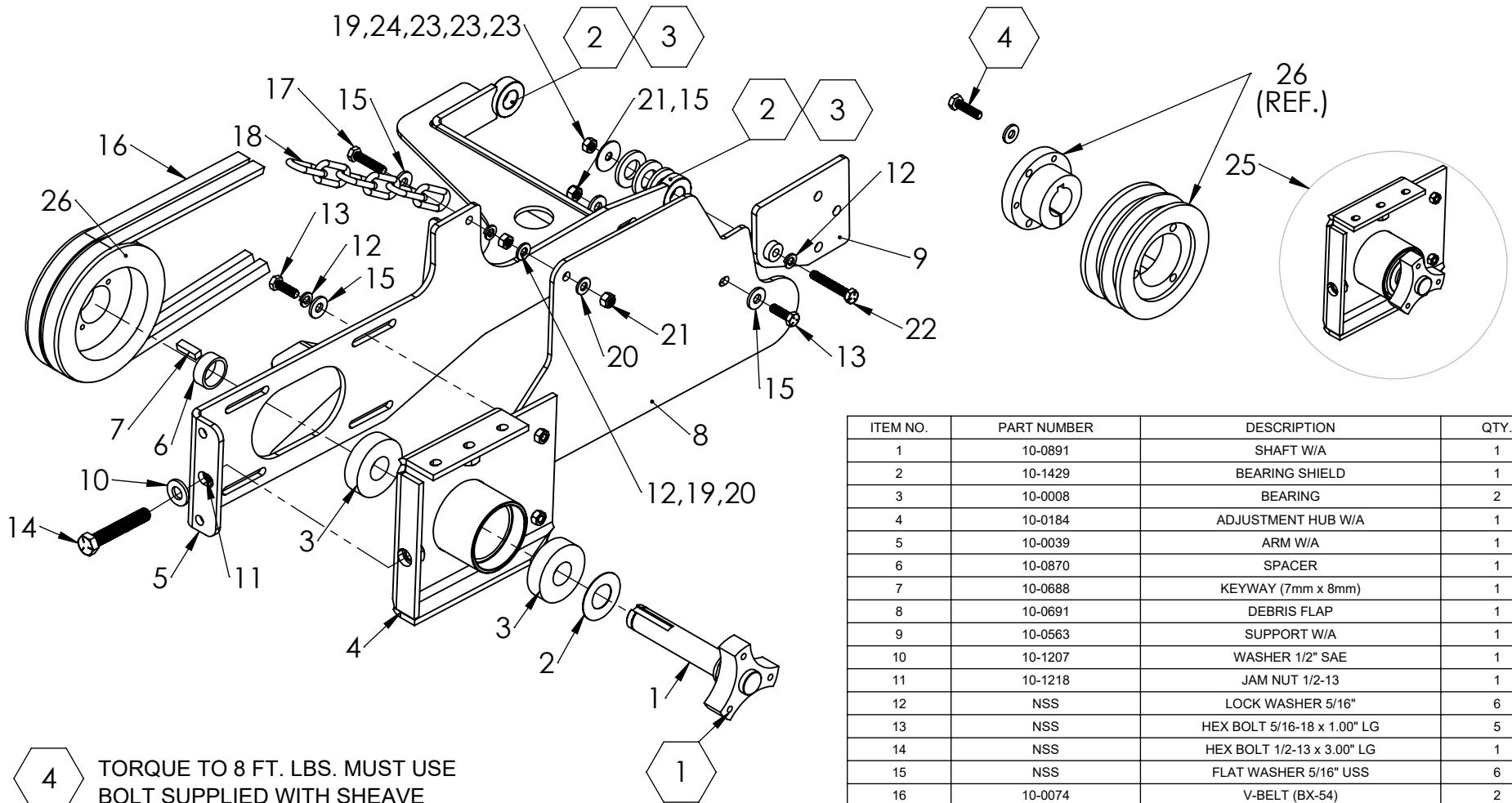

- 4** TORQUE TO 8 FT. LBS. MUST USE BOLT SUPPLIED WITH SHEAVE
- 3** APPLY ANTI-SEIZE LUBRICANT
- 2** REAM OUT TO .751/.753 DIA.
- 1** TAP THREADS

NOTE: ALL HARDWARE IS GRADE 5, PLATED AND COARSE THREAD UNLESS OTHERWISE SPECIFIED.

ITEM NO.	PART NUMBER	DESCRIPTION	QTY.
1	10-0891	SHAFT W/A	1
2	10-1429	BEARING SHIELD	1
3	10-0008	BEARING	2
4	10-0184	ADJUSTMENT HUB W/A	1
5	10-0039	ARM W/A	1
6	10-0870	SPACER	1
7	10-0688	KEYWAY (7mm x 8mm)	1
8	10-0691	DEBRIS FLAP	1
9	10-0563	SUPPORT W/A	1
10	10-1207	WASHER 1/2" SAE	1
11	10-1218	JAM NUT 1/2-13	1
12	NSS	LOCK WASHER 5/16"	6
13	NSS	HEX BOLT 5/16-18 x 1.00" LG	5
14	NSS	HEX BOLT 1/2-13 x 3.00" LG	1
15	NSS	FLAT WASHER 5/16" USS	6
16	10-0074	V-BELT (BX-54)	2
17	NSS	HEX BOLT 5/16-18 x 1.50" LG	1
18	10-0612	EDGER LIFT CHAIN - 13 LINKS	1
19	10-1225	HEX NUT 5/16-18	2
20	NSS	FLAT WASHER 5/16"	2
21	10-1225	LOCK NUT 5/16-18	2
22	NSS	HEX BOLT 5/16-18 x 2.00" LG	1
23	10-1211	3/4" MACHINE WASHER	3
24	10-1104	WASHER 5/16" FENDER 1-1/4" x .34"	1
25	10-1529	ASSEMBLED ADJUSTMENT HUB; INCLUDES ITEMS: 1,2,3,&4.	1
26	10-0863	SHEAVE (6" DIA)	1

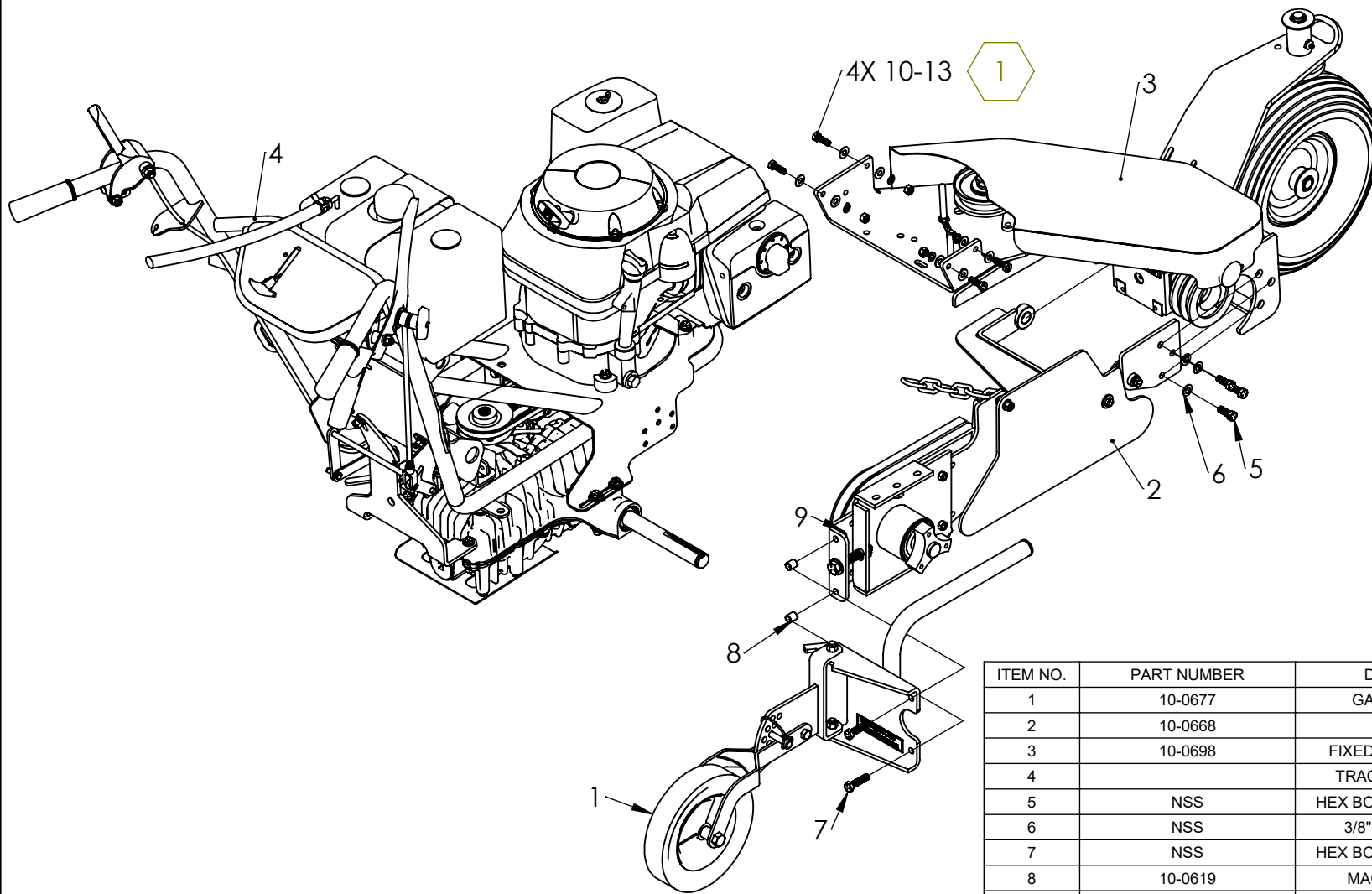

1 TORQUE TO 37 FT-LBS

ALL HARDWARE IS GRADE 5, PLATED AND COARSE
THREAD UNLESS OTHERWISE SPECIFIED

ITEM NO.	PART NUMBER	DESCRIPTION	QTY.
1	10-0677	GAUGE WHEEL A	1
2	10-0668	ARM A	1
3	10-0698	FIXED FRAME FRONT A	1
4		TRACTOR ASSEMBLY	1
5	NSS	HEX BOLT 3/8-16 x 1.00" LG	3
6	NSS	3/8" LOCK WASHER	3
7	NSS	HEX BOLT 3/8-16 x 1.50" LG	2
8	10-0619	MACHINE SPACER	2
9	10-1215	3/8-16 LOCKNUT	2
10	10-1228	GR 8. HEX BOLT 5/16-18 X 1.00"	4
11	NSS	5/16" FLAT WASHER	8
12	NSS	5/16-18 NUT	4
13	NSS	5/16" LOCK WASHER	4

TURFTEQ		11/6/18
	MODEL 1304 H/B	FIXED FRAME A

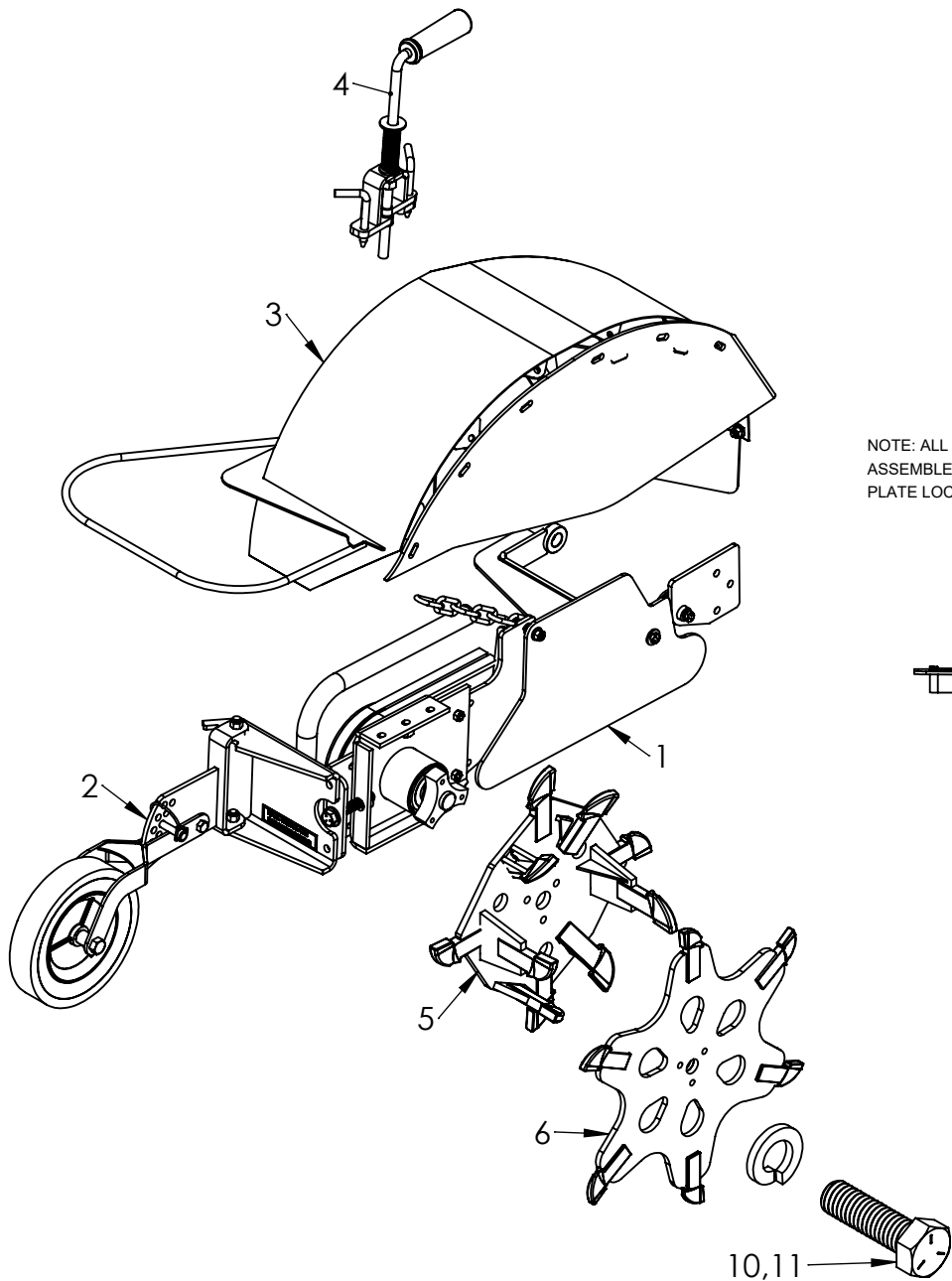

NOTE: ALL HARDWARE IS GRADE 5, PLATED AND COARSE THREAD UNLESS OTHERWISE SPECIFIED

HARDWARE SCALED UP FOR CLARITY

NOTE: ALL BLADES SHOULD BE ASSEMBLED WITH MOUNTING PLATE LOCATED ON THIS SIDE

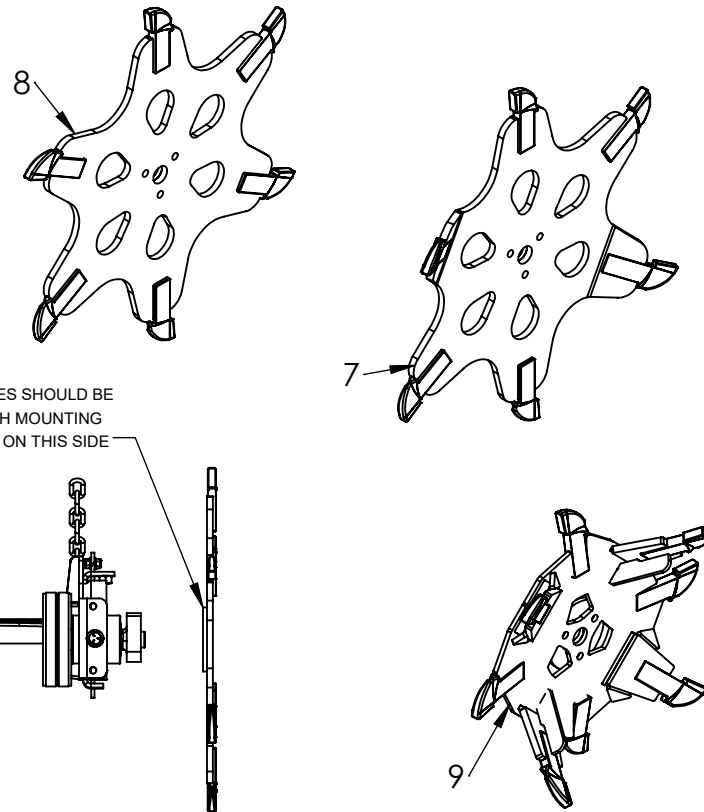

ITEM NO.	PART NUMBER	DESCRIPTION	QTY.
1	10-0668	ARM A	1
2	10-0677	GAUGE WHEEL A	1
3	G2	OPEN/TRENCH SHIELD A	1
4	10-0671	COVER CLAMP A	1
5	16T	OPENER BLADE	1
6	T3	2" x 7" TRENCH BLADE	1
7	T3W	2-1/2" x 7" TRENCH BLADE	1
8	T3N	1/2" x 7" TRENCH BLADE	1
9	T4	5" x 5" TRENCH BLADE	1
10	NSS	HEX BOLT 3/8"-16 x 1-1/4" LG	1
11	NSS	3/8" LOCK WASHER	1

TURFTEQ

10/3/18

MODEL 1304 H

OPENER/TRENCHER
BLADE COVER A

PAGE 20